

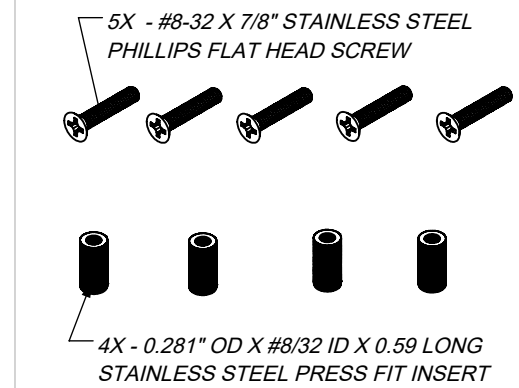

PART NUMBER	FINISH	SPECS
RFX-ADJ-OTP-MI	MILL	RAW
RFX-ADJ-OTP-BL	BLACK	PAINTED
RFX-ADJ-OTP-BZ	BRONZE	PAINTED
RFX-ADJ-OTP-WH	WHITE	PAINTED
RFX-ADJ-OTP-SI	SILVER	PAINTED
RFX-ADJ-OTP-AN	ANODIZED	ANODIZED

ECR/DCR		REV.	REVISIONS		DATE	APPD
DESCRIPTION						
-	-		INITIAL RELEASE		12-2-20	-

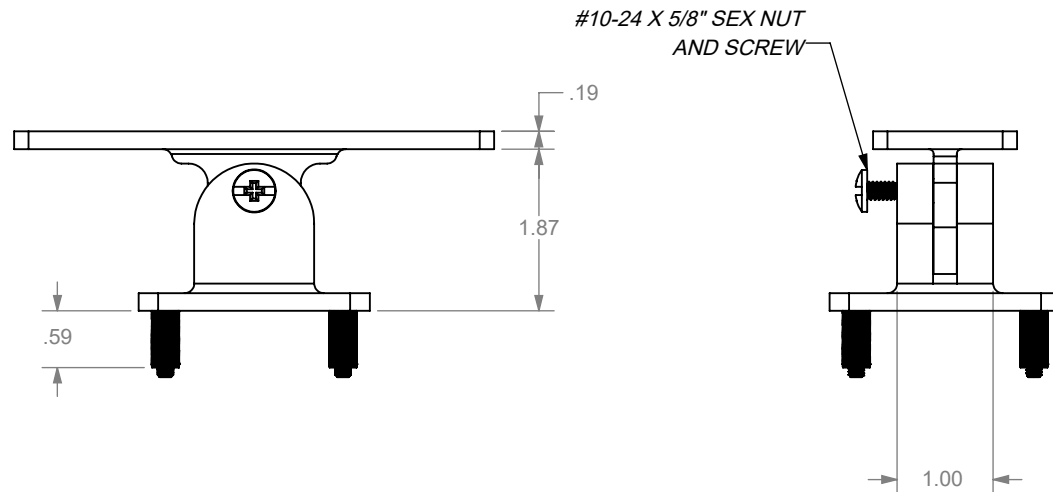
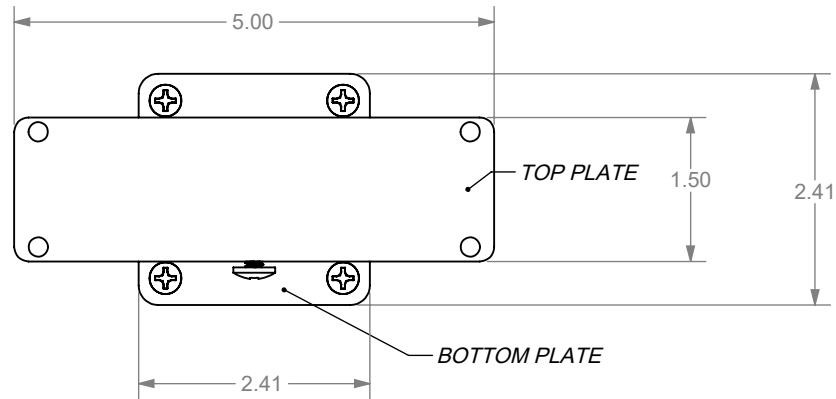
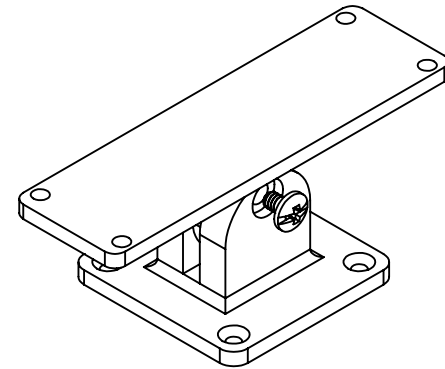

- NOTES:**
- EXTRA SCREW PROVIDED TO HELP INSERT THE PRESS FIT INSERT INTO POST
 - TIGHTEN SEX NUT AFTER ANGLE OF TOP RAIL IS DETERMINED

DIMENSIONS ARE IN INCHES TOLERANCES: FRACTIONAL $\pm 1/16"$ ANGULAR: MACH $\pm 1^\circ$ BEND $\pm 1^\circ$ TWO PLACE DECIMAL ± 0.01 THREE PLACE DECIMAL ± 0.005		 <p>RailFX CABLE • SPECIALTY RFX ADJUSTABLE OVER THE POST FITTING</p>
PROPRIETARY AND CONFIDENTIAL THE INFORMATION CONTAINED IN THIS DRAWING IS THE SOLE PROPERTY OF NATIONWIDE INDUSTRIES. ANY REPRODUCTION IN PART OR AS A WHOLE WITHOUT THE WRITTEN PERMISSION OF NATIONWIDE INDUSTRIES IS PROHIBITED.		
SIZE: A	DWG. NO. CS-RFX-ADJ-OTP	REV. -
SCALE: 1:2	WEIGHT:	SHEET 1 OF 1