

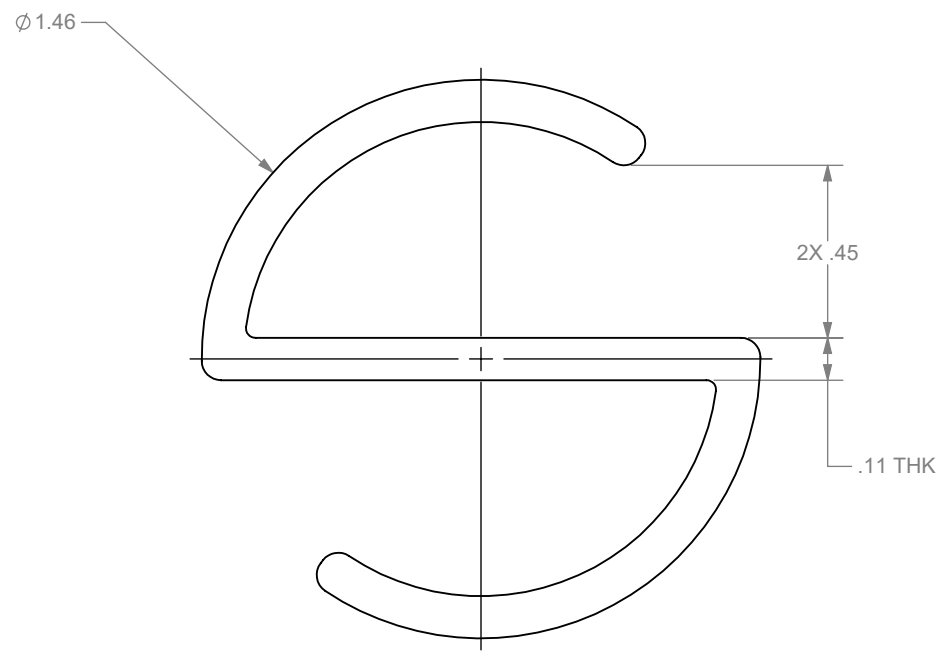

ECR/DCR		REV.	REVISIONS	DESCRIPTION	DATE	APPD
-	-	-	INITIAL RELEASE		2-24-21	DHL



DIMENSIONS ARE IN INCHES TOLERANCES: FRACTIONAL $\pm 1/16"$ ANGULAR: MACH $\pm 1^\circ$ BEND $\pm 1^\circ$ TWO PLACE DECIMAL ± 0.01 THREE PLACE DECIMAL ± 0.005		 RailFX CABLE • SPECIALTY RFX ADA HANDRAIL INTERNAL SPLICE
PROPRIETARY AND CONFIDENTIAL THE INFORMATION CONTAINED IN THIS DRAWING IS THE SOLE PROPERTY OF NATIONWIDE INDUSTRIES. ANY REPRODUCTION IN PART OR AS A WHOLE WITHOUT THE WRITTEN PERMISSION OF NATIONWIDE INDUSTRIES IS PROHIBITED.		
SIZE A	DWG. NO. CS--RFXADASINT	REV. 1
SCALE: 2:1	WEIGHT:	SHEET 1 OF 1