

PART NUMBER	FINISH	SPECS
RFXADACAP-MI	MILL	RAW
RFXADACAP-BL	BLACK	AAMA 2604 POWDER COAT
RFXADACAP-BZ	BRONZE	AAMA 2604 POWDER COAT
RFXADACAP-WH	WHITE	AAMA 2604 POWDER COAT
RFXADACAP-SI	SILVER	AAMA 2604 POWDER COAT
RFXADACAP-AN	ANODIZED	215R 1 CLASS 1 CLEAR

ECR/DCR		REV.	REVISIONS		DATE	APPD
			DESCRIPTION			
-	-		INITIAL RELEASE		2-24-21	DHL

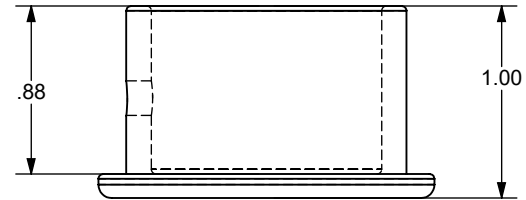
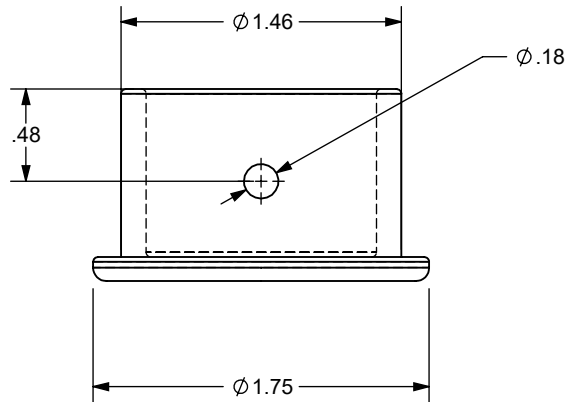
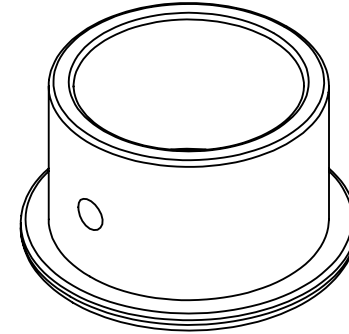
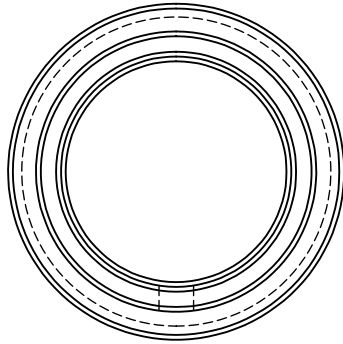

RFXADACAP
MATERIAL: A360 CAST ALUMINUM

DIMENSIONS ARE IN INCHES
TOLERANCES:
FRACTIONAL $\pm 1/16"$
ANGULAR: MACH $\pm 1^\circ$ BEND $\pm 1^\circ$
TWO PLACE DECIMAL ± 0.01
THREE PLACE DECIMAL ± 0.005

PROPRIETARY AND CONFIDENTIAL
THE INFORMATION CONTAINED IN THIS DRAWING IS THE SOLE PROPERTY OF NATIONWIDE INDUSTRIES. ANY REPRODUCTION IN PART OR AS A WHOLE WITHOUT THE WRITTEN PERMISSION OF NATIONWIDE INDUSTRIES IS PROHIBITED.



RAILFX
ADA HAND RAIL
END CAP

SIZE A	DWG. NO. CS--RFXADACAP	REV. -
SCALE: 1:1	WEIGHT:	SHEET 1 OF 1