

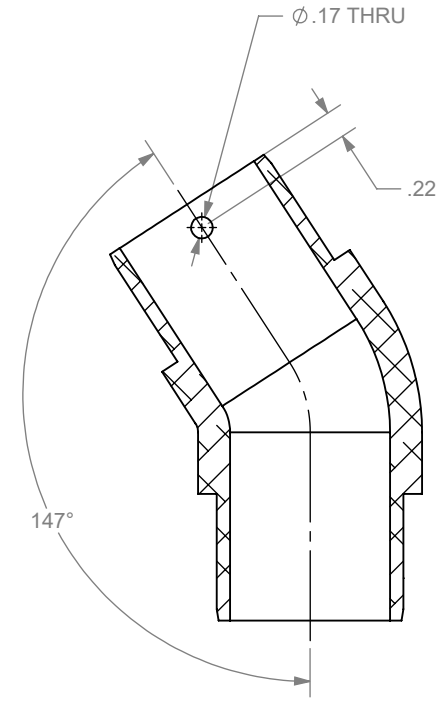

PART NUMBER	FINISH	SPECS
RFXADAHR33-MI	MILL	RAW
RFXADAHR33-BL	BLACK	AAMA 2604 POWDER COAT
RFXADAHR33-BZ	BRONZE	AAMA 2604 POWDER COAT
RFXADAHR33-WH	WHITE	AAMA 2604 POWDER COAT
RFXADAHR33-SI	SILVER	AAMA 2604 POWDER COAT
RFXADAHR33-AN	ANODIZED	215R 1 CLASS 1 CLEAR

ECR/DCR		REV.	REVISIONS		DATE	APPD
-	-	-	DESCRIPTION	INITIAL RELEASE	2-24-21	DHL

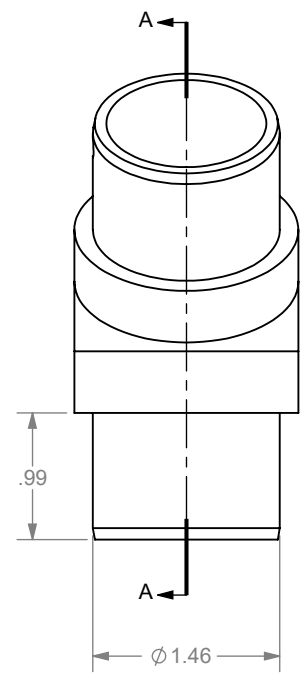
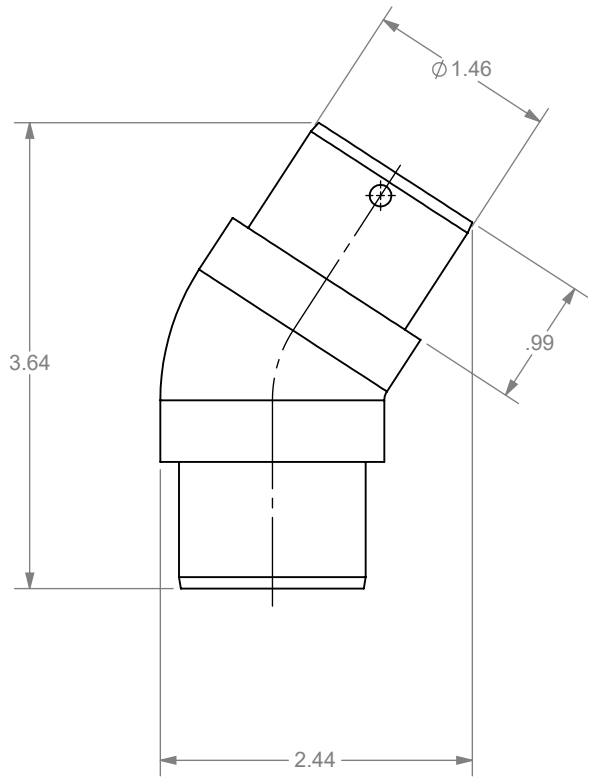
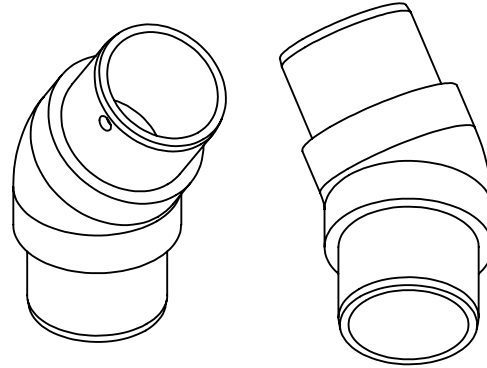

SECTION A-A

RFXADAHR33
MATERIAL: A360 CAST ALUMINUM

DIMENSIONS ARE IN INCHES TOLERANCES: FRACTIONAL $\pm 1/16"$ ANGULAR: MACH $\pm 1"$ BEND $\pm 1"$ TWO PLACE DECIMAL ± 0.01 THREE PLACE DECIMAL ± 0.005		 CABLE • SPECIALTY RAILFX 33° ADA HAND RAIL CONNECTOR
PROPRIETARY AND CONFIDENTIAL THE INFORMATION CONTAINED IN THIS DRAWING IS THE SOLE PROPERTY OF NATIONWIDE INDUSTRIES. ANY REPRODUCTION IN PART OR AS A WHOLE WITHOUT THE WRITTEN PERMISSION OF NATIONWIDE INDUSTRIES IS PROHIBITED.		
SIZE: A DWG. NO.: CS--RFXADAHR33 SCALE: 2:3	REV. NO.: - WEIGHT:	SHEET 1 OF 1