

PART NUMBER	FINISH	SPECS
RFXADAHRMF90-MI	MILL	RAW
RFXADAHRMF90-BL	BLACK	AAMA 2604 POWDER COAT
RFXADAHRMF90-BZ	BRONZE	AAMA 2604 POWDER COAT
RFXADAHRMF90-WH	WHITE	AAMA 2604 POWDER COAT
RFXADAHRMF90-SI	SILVER	AAMA 2604 POWDER COAT
RFXADAHRMF90-AN	ANODIZED	215R 1 CLASS 1 CLEAR

ECR/DCR		REV.	REVISIONS		DATE	APPD
			DESCRIPTION			
-	-		INITIAL RELEASE		2-24-21	DHL

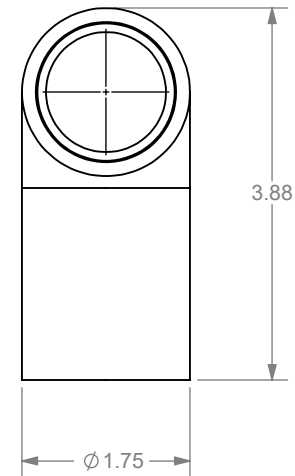
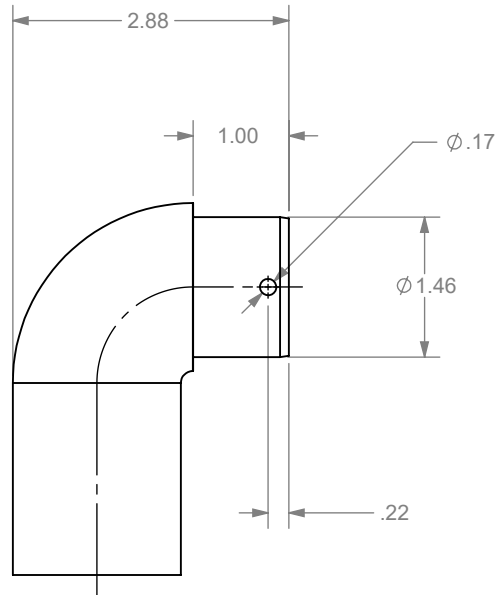
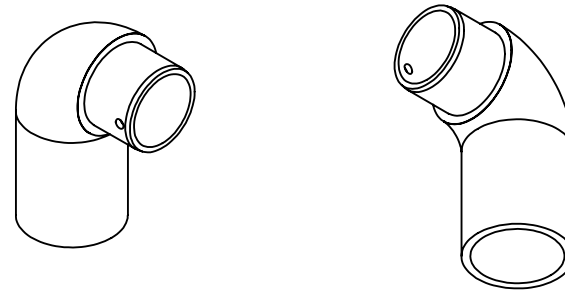

**RFXADAHRMF90**  
MATERIAL: A360 CAST ALUMINUM

DIMENSIONS ARE IN INCHES  
TOLERANCES:  
FRACTIONAL  $\pm 1/16"$   
ANGULAR: MACH  $\pm 1^\circ$  BEND  $\pm 1^\circ$   
TWO PLACE DECIMAL  $\pm 0.01$   
THREE PLACE DECIMAL  $\pm 0.005$

**PROPRIETARY AND CONFIDENTIAL**  
THE INFORMATION CONTAINED IN THIS DRAWING IS THE SOLE PROPERTY OF NATIONWIDE INDUSTRIES. ANY REPRODUCTION IN PART OR AS A WHOLE WITHOUT THE WRITTEN PERMISSION OF NATIONWIDE INDUSTRIES IS PROHIBITED.



**RAILFX ADA HAND RAIL  
90° MALE-FEMALE HAND RAIL  
CONNECTOR**

SIZE <b>A</b>	DWG. NO. <b>CS--RFXADAHRMF90</b>	REV. -
SCALE: 1:2	WEIGHT:	SHEET 1 OF 1