

# FlexFX INSTALLATION INSTRUCTIONS

FOR WOOD, WOOD WRAPPED, AND COMPOSITE SLEEVE POSTS

## TOOLS REQUIRED FOR INSTALLATION

- Tape measure
- Cordless drill
- T25 screw bit
- RailFX Universal Drilling Template\*
- RailFX Flex Cable Install Kit (IN STL-KIT-FLEX-WD)\*
- Cable Cutters (C-7HIT)\*

\*sold separately

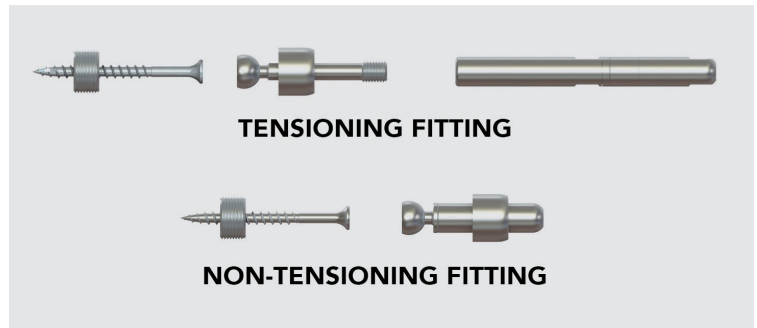



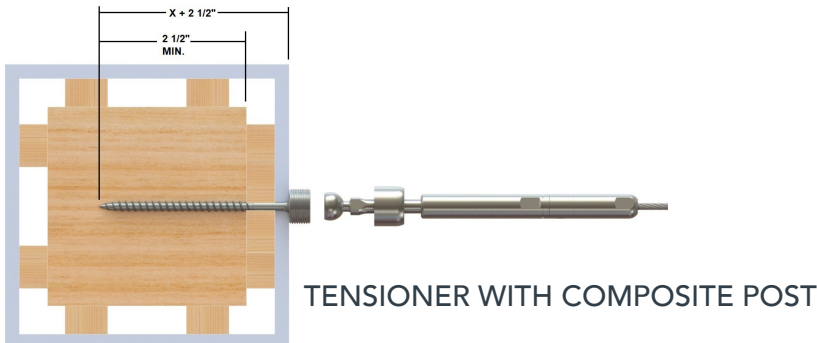

**NOTE:** Same fitting is used for level and stair applications.

**TO MEET CODE REQUIREMENTS, CABLES MUST NOT SPAN MORE THAN 4' WITHOUT A POST OR CABLE SUPPORT BRACE.**



**NOTE:** If using Flex Fittings with a composite sleeve or wrapped post, alternative screws will need to be purchased that will provide 2-1/2" of embedment to the structural post.

### SCREW LENGTHS FOR VARIOUS POST SIZES

-  4X4 POST (3-1/2" X 3-1/2") - 2-1/2" LENGTH SCREW REQUIRED
-  4X4 POST W/ 4.5" SLEEVE (4-1/2" X 4-1/2") - 3" LENGTH SCREW REQUIRED
-  4X4 POST W/ 5.1" SLEEVE (5.1" X 5.1") - 3-1/2" LENGTH SCREW REQUIRED
-  4X4 POST W/ 5.5" SLEEVE (5-1/2" X 5-1/2") - 3-1/2" LENGTH SCREW REQUIRED



SCAN HERE FOR STEP-BY-STEP  
INSTALLATION VIDEO

**LEAN ON US.**

P: 206.453.1123 | railfx.net

### STEP 1:

Drill posts for cable and fittings using the RailFX Universal Post Drilling Template. If not using the drilling template, use a tape measure and mark 3-1/8" from bottom of top rail to first hole. Note: cable spacing is 3-1/8".

### END POSTS:

- Using RFX Universal Drilling Template, clamp the template to the inside face of each end post, aligning the top side of the template to the underside of the top rail and center the template to the post.

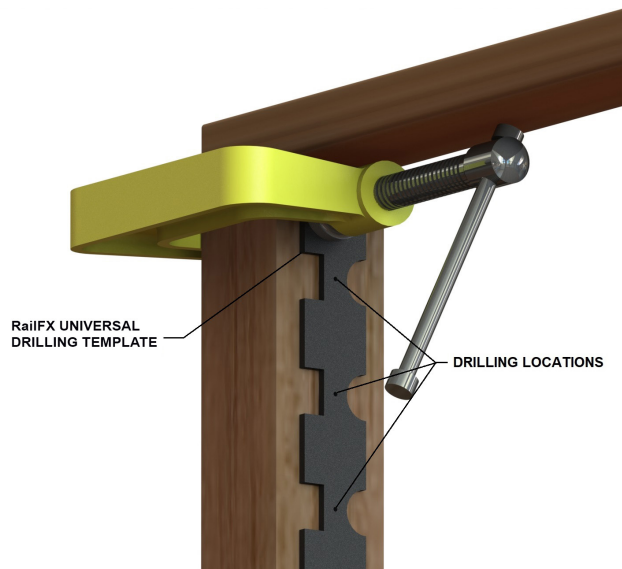

- Using a 1/8" drill bit, drill approximately 1/4" into the post. This will mark where each fitting will be attached to the post with the supplied 2-1/2" screw.
- Using a T25 bit, attach Flex Mounting Cups (FF-MC-W) to the post using the supplied 2-1/2" Stainless Steel Screw or longer screws (sold separately) for sleeved posts. It may be necessary to pre-drill before the mounting bases are installed if screws are being installed into a hard wood.

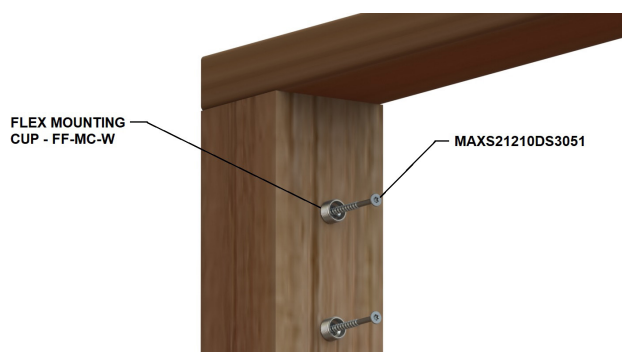

- Attach all non-tensioning and tensioning hardware to the mounting bases. (**Note:** Make sure all tensioning fittings are adjusted to the same location - ensuring enough thread turns remain for final tensioning of the cables).

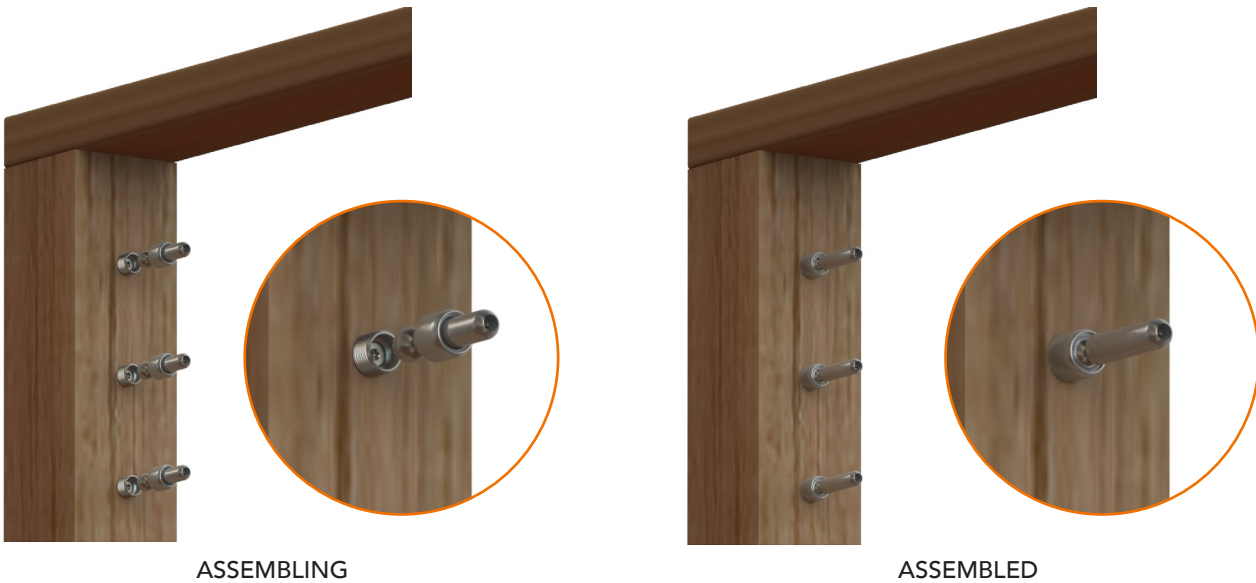

## STEP 2: DRILL INTERMEDIATE POSTS

- Each intermediate post will need to be drilled all the way through so the cable can pass through to the next intermediate post or end post. Center and clamp Universal Post Drilling Template to one side of the intermediate post. Mark hole locations with pen or marker for each hole in the template. Then move the template to the other side of the post and repeat this process for all intermediate posts.



- Remove template and, using a 7/32" drill bit, drill halfway through posts for all holes on each side of post.

**NOTE:** If cable is transitioning out of the post at an angle, use RFX Post Protector Tubes (CS-TUBE). Holes in post must be 1/4" diameter for installation of CS-TUBE.

### STEP 3: INSTALL AND TENSION CABLES

- Using 100' or 500' bulk cable, lace cable through the intermediate post starting at the end the tensioning fittings are installed. Use Cable Lacing Needle included in the RailFX installation kit (**INSTL-KIT-FLEX-WD**).

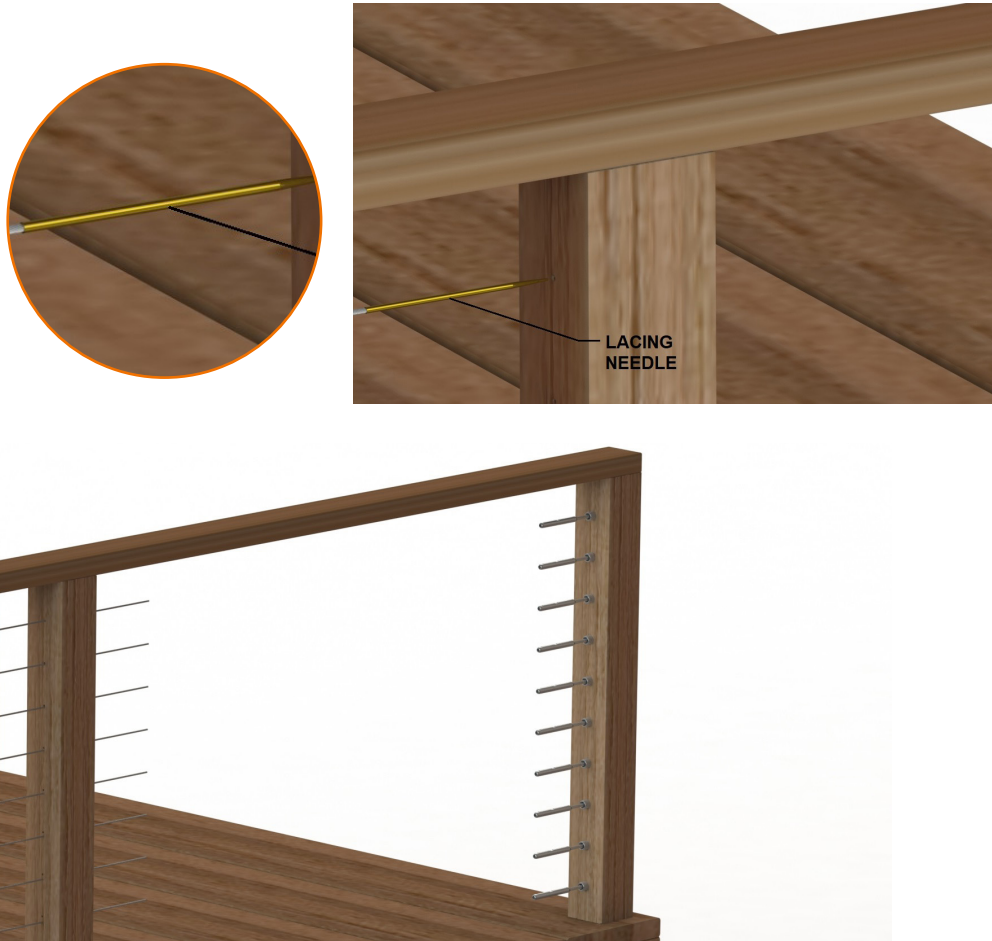

- Push cable into the non-tensioning fitting by pushing cable into fitting while rotating cable in a clockwise direction. After insertion, stop rotating cable and push in. This will keep the cable from unraveling.

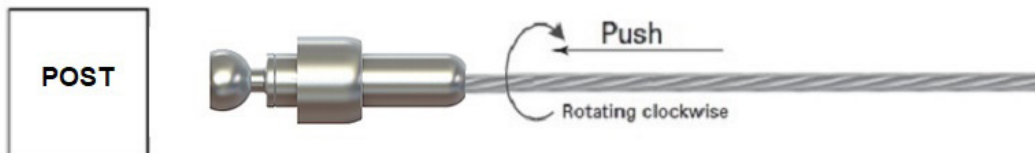

- Go to the other end of the cable and pull cable tight and align cable with cut mark on the tensioning end fitting. Mark cable and cut with RFX cable cutters (C-7HIT).

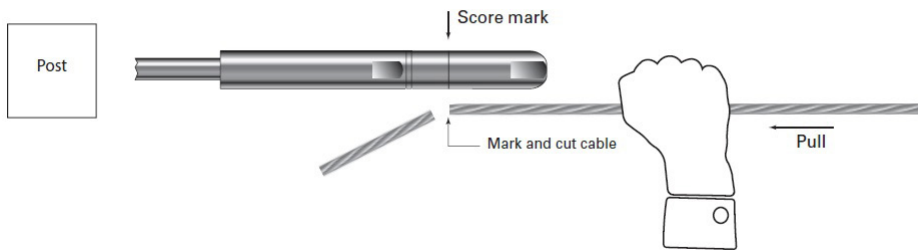

- Push cable into the Tensioning fitting by pushing cable into fitting while rotating cable in a clockwise direction. After insertion, stop rotating cable and push in. This will keep the cable from unraveling. Repeat this process for each run of cable.



- Tension cable using the wrenches in the RFX installation kit. Tension all cables to specified tension of 225 lbs., beginning with the center cables, moving up and down toward the top and bottom. As you tension each cable, give it a sharp pull downward mid-span to help set the wedges, then re-tension as necessary in the same sequence. Be aware that the cable may move as much as 3/16" toward the tensioning terminal as the wedges seat.

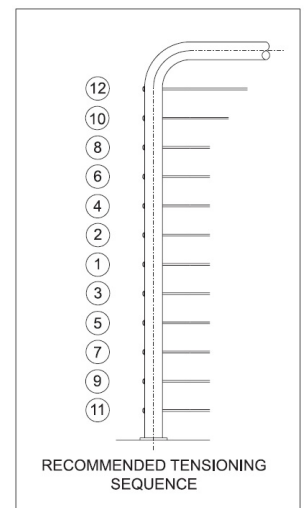
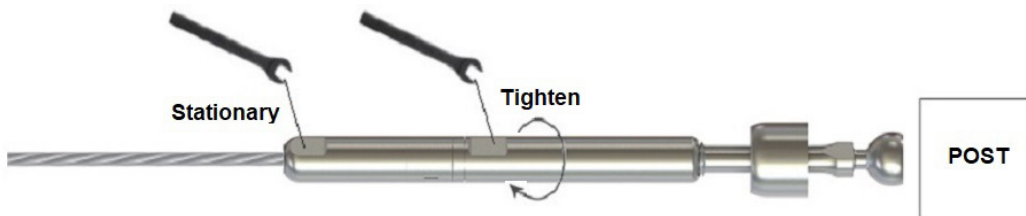

SCAN HERE FOR STEP-BY-STEP  
INSTALLATION VIDEO

**LEAN ON US.**

P: 206.453.1123 | railfx.net